

CLASSIFICATION Einstufung		No. DS-Eval4570-2400	REV. C
SUBJECT Thema		EvalBoard PAN4570	
CUSTOMER'S CODE EvalPAN4570		PANASONIC'S CODE	DATE Datum
		PAGE Seite	
		1 of 20	
		06.11.2006	



Manual
Evaluation-Board for
PAN4570 Wireless Module

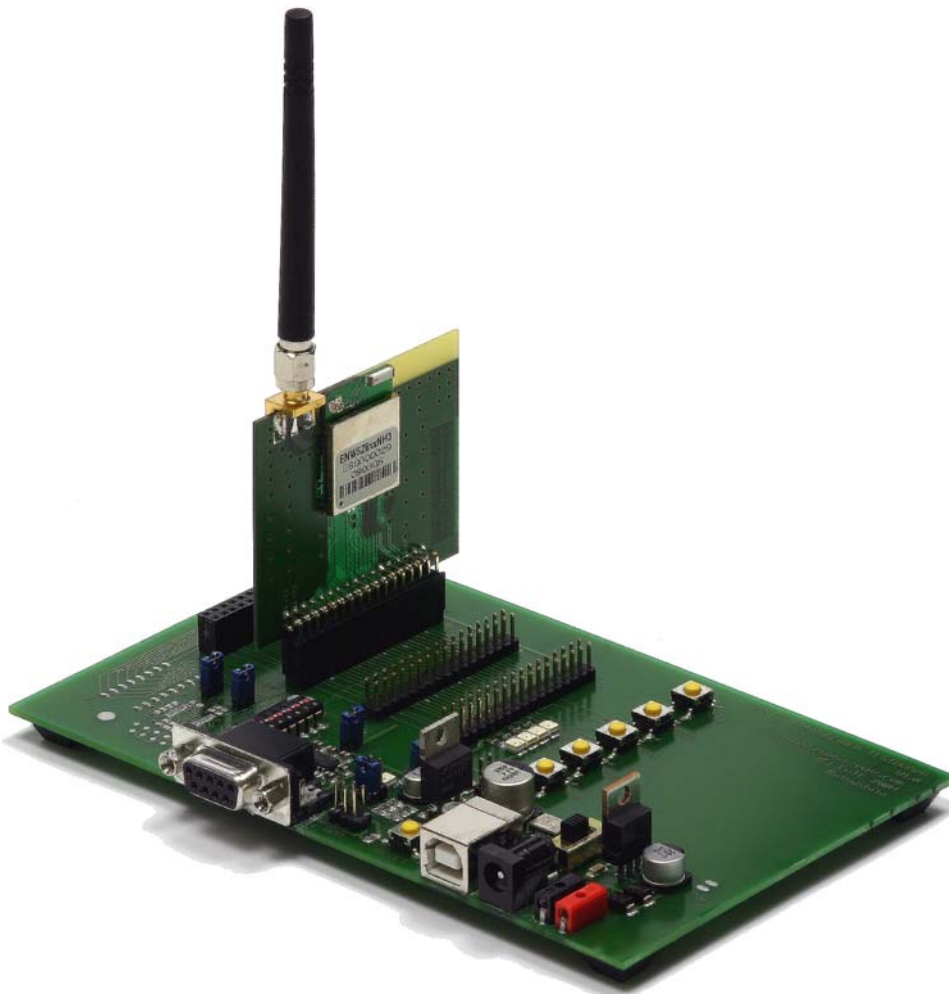

FIGURE 1 ISM RF TRANSCEIVER TESTBOARD WITH PAN4570 AND ANTENNA

European Technology Center Panasonic Electronic Devices (EUROPE) GmbH	APPROVED genehmigt	CHECKED geprüft	DESIGNED Erstellt
--	-----------------------	--------------------	----------------------

CLASSIFICATION Einstufung	No. DS-Eval4570-2400	REV. C
SUBJECT Thema	EvalBoard PAN4570	
CUSTOMER'S CODE EvalPAN4570	PANASONIC'S CODE	DATE Datum
		06.11.2006

TABLE OF CONTENTS

1. Overview	3
1.1. Contents of the Evaluation Kit:.....	3
1.2. Hardware needed.....	3
1.3. Software needed	3
2. Setting up the EvalBoard.....	4
3. Testboard Layout	5
4. Operation of the testboard.....	6
5. Power Supply	6
5.1. D.C. power from a power supply.....	6
5.2. D.C. power from a USB device:	7
5.3. Power on	7
6. Serial Port.....	8
7. Reset.....	8
8. Operation and programming	8
8.1. Serial communication and embedded bootloader	8
8.2. Upload of EmberZNet sample applications.....	9
8.3. Selecting the hardware platform	10
8.4. Ember™ Insight Adaptor configuration	11
9. Ember ZigBee Implementation.....	11
9.1 Flash Programming of PAN4570	11
9.2. Development of Applications.....	14
9.3. Ember™ ZigBee stack	14
9.4. Testing for IEEE802.15.4 parameters.....	15
10. Schematic of the ISM RF TRANSCEIVER TESTBOARD.....	16
10.1 Sheet 1.....	16
10.2. Sheet 2.....	17
10.3. PAN4570 carrierboard	18
11. Related Documents.....	19
12. Document Status.....	19
13. History for this Document.....	19
14. General Information.....	20
15. Life Support Policy	20

European Technology Center Panasonic Electronic Devices (EUROPE) GmbH	APPROVED genehmigt	CHECKED geprüft	DESIGNED Erstellt
--	-----------------------	--------------------	----------------------

CLASSIFICATION Einstufung	No. DS-Eval4570-2400	REV. C
SUBJECT Thema	EvalBoard PAN4570	
CUSTOMER'S CODE EvalPAN4570	PANASONIC'S CODE	DATE Datum
		3 of 20
		06.11.2006

1. OVERVIEW

The EvalKit PAN4570 allows evaluation of the wireless module PAN4570. For a basic hardware evaluation the test software Ember Range Test Application V2.0 and the Ember™ embedded bootloader are programmed. The embedded bootloader can be used for loading other applications via the serial cable to PAN4570, for example the EmberZNet sample application "simple-lighting".

For more information see chapter 9.3.

1.1. CONTENTS OF THE EVALUATION KIT:

- 2 x ISM RF Transceiver Testboards
- 2 x PAN4570 mounted on a carrierboard
- 2 x 2,45GHz antennas with male SMA plugs
- 2 x RS-232 cables
- 2 x battery adaptors with cable for d. c. power supply
- 1 x CD with software and documentation

1.2. HARDWARE NEEDED

- 12 x Batteries (AA size) (or 2 mains supplied 9Vdc sources)
- PC with at least 1 (preferably 2) free COM Ports

1.3. SOFTWARE NEEDED

- Microsoft™ "Hyper Terminal" or any other terminal software installed on a pc
 - EmberZNet installed on a pc, currently Version 2.5.0
 - Ember™ xIDE for EM250 compiler and debugger installed on the pc where EmberZNet is installed on
 - Ember™ InSight Desktop installed on a pc for network development
 - Ember™ Range Test Application V2.0 (Version Oct. 1 2006). This basic hardware test software and the EmberZNet sample application "simple-lighting" are ready for programming included on the CD within this kit.
- Programming and debugging with Ember™ xIDE requires at least 1 Ember™ Insight Adaptor.
- Loading an image file (.ebl as output from xIDE) to PAN4570 via the included serial cable is possible as well, in this case the Insight Adaptor is not needed

European Technology Center Panasonic Electronic Devices (EUROPE) GmbH	APPROVED genehmigt	CHECKED geprüft	DESIGNED Erstellt
--	-----------------------	--------------------	----------------------

CLASSIFICATION Einstufung	No. DS-Eval4570-2400	REV. C
SUBJECT Thema	EvalBoard PAN4570	
CUSTOMER'S CODE EvalPAN4570	PANASONIC'S CODE	DATE Datum
		4 of 20
		06.11.2006

Important: To install and run the programs you need Administrator rights on the test PC.
Check for software updates at www.Ember.com.

2. SETTING UP THE EVALBOARD

Plug a PAN4570 Carrierboard on one of the three 34-pins headers (B or C or D) as shown in Figures 1 and 2. Please take care that pin 1 of the Carrierboard connects to pin1 of the testboard according to the "1" marking on the PCBs.

Important: Only 1 PAN4570 carrierboard may be plugged on the testboard.

The other 34-pin headers/sockets are provided for demo application boards like sensors, actuators, etc. On slot A a socket is mounted instead of double pin rows for applications using a plug with pins. For details on the testboard see chapter 3 and the testboard schematic in chapter 10.

Mount the 50Ohms 2,4GHz antenna with SMA male plug on the PAN4570 carrierboard SMA socket.

Check if a Vcc=+2,7Vdc module supply jumper is set to the corresponding 2-pin header (B or C or D).

Remark: Instead of a jumper an amperemeter for measuring the module current on VCC can be connected to the module supply 2-pin header. In this case the voltage drop at the amperemeters internal resistor reduces the Vcc voltage applied to PAN4570 depending on the current drawn. Therefore check if the amperemeter used has an internal resistance of sufficiently low value.

As an option a +5Vdc regulated voltage is available on the 34-pins headers (this does not apply to usage of USB as power supply).

Important: Do not connect the +5Vdc directly to PAN4570 because it may damage the Module.

The reason for the +5Vdc option are applications needing a higher supply voltage (i.e. with white LEDs). In order to use +5Vdc on the headers it has to be connected by plugging a jumper to position JP2.

The total available current from Vcc plus the current from +5Vdc is approximately 270mA maximum, provided that the power source voltage applied to P1-P2-P3 does not drop below approximately 6,6Vdc.

For the location of switches and jumpers on the Evaluation board see [chapter 3](#).

European Technology Center Panasonic Electronic Devices (EUROPE) GmbH	APPROVED genehmigt	CHECKED geprüft	DESIGNED Erstellt
--	-----------------------	--------------------	----------------------

CLASSIFICATION Einstufung	No. DS-Eval4570-2400	REV. C
SUBJECT Thema	EvalBoard PAN4570	
CUSTOMER'S CODE EvalPAN4570	PANASONIC'S CODE	DATE Datum
		5 of 20
		06.11.2006

3. TESTBOARD LAYOUT

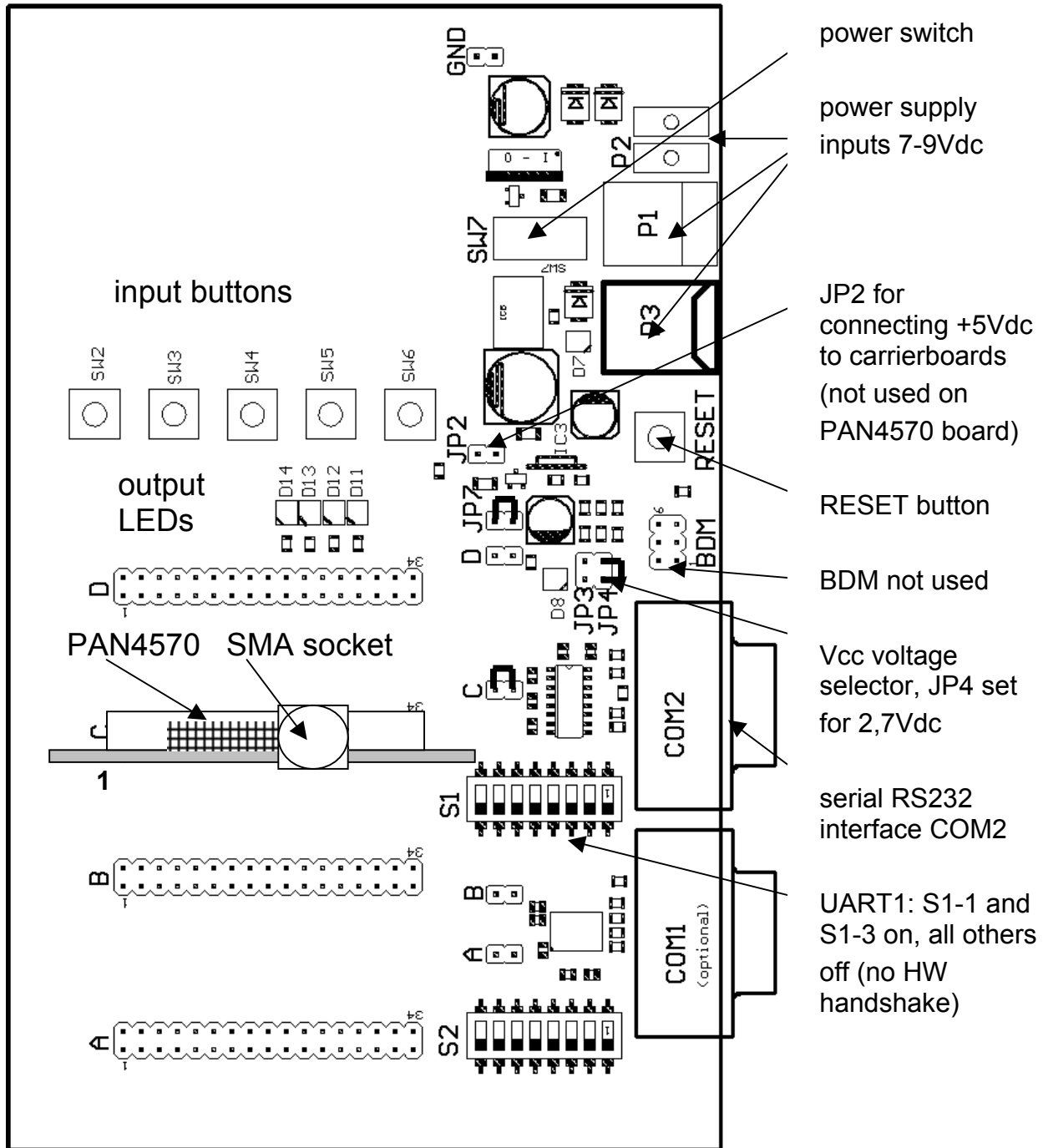

Figure 2 ISM RF Transceiver testboard with PAN4570 and antenna

European Technology Center Panasonic Electronic Devices (EUROPE) GmbH	APPROVED genehmigt	CHECKED geprüft	DESIGNED Erstellt
--	-----------------------	--------------------	----------------------

CLASSIFICATION Einstufung	No. DS-Eval4570-2400	REV. C
SUBJECT Thema	EvalBoard PAN4570	
CUSTOMER'S CODE EvalPAN4570	PANASONIC'S CODE	DATE Datum
		6 of 20
		06.11.2006

4. OPERATION OF THE TESTBOARD

If not already done please follow the basic setting up instructions as in [Chapter 2](#)
Check if the jumper plugs are set as indicated in Figure 2. The functions of the jumpers are as follows:

jumper me	function	to set as in Figure 2
A	Vcc for position A	do not care
B	Vcc for module at position B*	do not care
C	Vcc for module at position C*	yes
D	Vcc for module at position D*	do not care
JP2	5Vdc feed to Slots A, B, C, D**	no
JP3	Vcc setting 2.1-2.7-3.4V; see Table 2	no for Vcc=2.7Vdc default
JP4	Vcc setting 2.1-2.7-3.4V; see Table 2	yes for Vcc=2.7Vdc default
JP7	Vcc regulator output feed to A, B, C, D	yes

(Table 1)

- * Position C is used as an example, position B or D could be used as well.
An amperemeter for measuring module current can be inserted instead of the jumper
- ** +5Vdc supply (independent on JP3 and JP4 settings) option is provided for application demos. The +5Vdc supply is NOT used on PAN4570 carrierboard.

Check if the port switches S1 near to the COM2 connector for RS232 are all set to off position except the selected UART as noted in Figure 2/Table 3.

5. POWER SUPPLY

5.1. D.C. POWER FROM A POWER SUPPLY

Set the power switch SW7 to the position 2 = off.
Connect a power supply with 7-9VDC to one of the power inputs (P1 or P2).

In case of P1 use a plug with 5,5mm diameter and the positive terminal at the centre contact.

European Technology Center Panasonic Electronic Devices (EUROPE) GmbH	APPROVED genehmigt	CHECKED geprüft	DESIGNED Erstellt
--	-----------------------	--------------------	----------------------

CLASSIFICATION Einstufung	No. DS-Eval4570-2400	REV. C
SUBJECT Thema	EvalBoard PAN4570	
CUSTOMER'S CODE EvalPAN4570	PANASONIC'S CODE	DATE Datum
		7 of 20
		06.11.2006

For use of the P2 2mm contacts the black socket P2-X1 is the negative/ground contact and the red socket P2-X2 is the positive terminal.

A linear regulator on the testboard regulates the input voltage down to the +5V DC board supply. A second linear regulator regulates the +5V DC down to the module VCC supply of 2,1/2,7/3,4Vdc.

5.2. D.C. POWER FROM A USB DEVICE:

In case no dedicated supply is available, DC supply can be taken from an USB connection. The +5V DC from the USB feeds the linear regulator for the modules VCC supply of 2,1/2,7/3,4Vdc (see Table 1).

Please note that communication via the USB connector is **not** possible.

Please take into account that when using the +5V DC feed to the 34-pin-headers in combination with USB power supply the voltage is not +5V but unregulated 4.3 V DC due to the voltage drop at a protection diode connected in series on the testboard.

Warning: Do not overload the USB power source. Check for the current available from your USB device in order to avoid malfunction of or damage to your USB power source.

5.3. POWER ON

Set SW7 to the position 1 = on. (With power from USB position 1 is off and position 2 is on). D7 should be lit indicating that +5Vdc supply is available on the testboard. D8 should be lit indicating that the regulated Vcc module supply is available.

The dc regulator output voltage is set with a jumper on JP3 or JP4 as follows:

jumper on 2-pin header	regulator output voltage VCC	remarks
JP4 only (default)	2,7 Vdc	typical for PAN4570
no jumpers	3,4 Vdc	Maximum for PAN4570
JP3 only	2,1 Vdc	Minimum for PAN4570

(Table 2)

European Technology Center Panasonic Electronic Devices (EUROPE) GmbH	APPROVED genehmigt	CHECKED geprüft	DESIGNED Erstellt
--	-----------------------	--------------------	----------------------

CLASSIFICATION Einstufung		No. DS-Eval4570-2400	REV. C
SUBJECT Thema		EvalBoard PAN4570	
CUSTOMER'S CODE EvalPAN4570		PANASONIC'S CODE	DATE Datum
			8 of 20
			06.11.2006

6. SERIAL PORT

The evalboard is equipped with a serial port connector, which is linked to UART1 (SCI1) of EM250. The S1 switch has to be set as follows:

UART1 active	1	2	3	4	5	6	7	8
S1 settings	ON	off	ON	off	off	off	off	off

(Table 3)

7. RESET

Reset of the boards on A,B,C or D can be done with the button named "RESET" next to the USB socket.

8. OPERATION AND PROGRAMMING

8.1. SERIAL COMMUNICATION AND EMBEDDED BOOTLOADER

As a first step connect the testboards with the serial cables to 1 or 2 pc's running terminal programs (for example Hyperterminal) with the following communication settings:

115200bps,8,parity no, Stoppbits 1, no flow control

After a hardware RESET and hitting the >return< key the terminal window of the PC connected to the RS232 interface of the ISM RF transceiver testboard should display

Ember Range Test Application v2.0

Oct 1 2006

Set to channel 0x0F

In order to do testing of basic hardware performance you could now proceed with commands described in chapter [9.4](#) . If you would like to run other applications, you could load an image file to PAN4570 as well. The chapter 0 describes loading the >simple-lighting< application from EmberZNet 2.5.0.

Launch the embedded bootloader typing in >bootload< and press the. The display now should read

EM250 Bootloader v20 b01

1. upload ebl

2. run

3. ebl info

>BL

Typing in >2< and hitting the >return< key would result in running the Ember™ Rargetest software again.

European Technology Center Panasonic Electronic Devices (EUROPE) GmbH	APPROVED genehmigt	CHECKED geprüft	DESIGNED Erstellt
--	-----------------------	--------------------	----------------------

CLASSIFICATION Einstufung	No. DS-Eval4570-2400	REV. C
SUBJECT Thema	EvalBoard PAN4570	
CUSTOMER'S CODE EvalPAN4570	PANASONIC'S CODE	DATE Datum
		9 of 20
		06.11.2006

8.2. UPLOAD OF EMBERZNET SAMPLE APPLICATIONS

Insert the cd coming with this kit into the drive of your pc and navigate to the folder \software\images. Here two image files are provided for the >simple-lighting< application, simple-lighting-light.ebl and simple-lighting-switch.ebl.

After launching the embedded bootloader load the "LIGHT"-image as follows:

On the terminal window type in >1<. The response should read:

begin upload

CCCCC.....

In the terminal program select the file transfer function, set the protocol to "Xmodem", select the simple-lighting-light.ebl as file and start the transfer. After successful upload the response from PAN4570 is

Serial upload complete

After pressing the RESET button on the testboard the output from PAN4570 is

simple light (<)00000000000000 offline

Network init status 93

Pressing SW2 results in D14 turned on and the output on the terminal

EVENT: light on

Pressing SW6 results in D14 turned off and the output on the terminal

EVENT: light off

On the other device run the procedure described above using the simple-lighting-switch.ebl instead. After pressing the RESET button on the testboard the output from PAN4570 as switch is:

simple switch (<)00000000000000 offline

Network init status 93

For a guide on operating "simple-lighting" see the Ember™ document \Ember\EmberZNet2.5.0\app\sampleApps.html as a part of the installation of EmberZNet on your pc. Please look at the folder \Ember\EmberZNet2.5.0\app\simple-lighting as well. The basic functionality is described in the simple-lighting.h file, while the operation and function of the buttons and LEDs are described in main.c. *Remark:* For the use of buttons and LEDs on the PAN4570 testboard with "simple-lighting" see also table 4 on the next page.

Following the button actions described in sampleApps.html (e. g. setting the coordinator, network joining and connecting) you can remotely switch the LIGHT D14 on and off.

If you would like to boot PAN4570 in embedded bootloader mode again, connect GPIO5 (pin 26 of the 34 pin connectors A-B-C-D on the testboard) to ground while the testboard power is switched to OFF. After switching the power ON again wait 2-3 seconds and remove the ground connection to GPIO5. Now you could upload another image file (for example the em250-rangetest.ebl which is on the cd as well), or run the application.

European Technology Center Panasonic Electronic Devices (EUROPE) GmbH	APPROVED genehmigt	CHECKED geprüft	DESIGNED Erstellt
--	-----------------------	--------------------	----------------------

CLASSIFICATION Einstufung	No. DS-Eval4570-2400	REV. C
SUBJECT Thema	EvalBoard PAN4570	
CUSTOMER'S CODE EvalPAN4570	PANASONIC'S CODE	DATE Datum
		10 of 20
		06.11.2006

8.3. SELECTING THE HARDWARE PLATFORM

The EmberZNet stack uses a Ember™ platform (Ember™ breakout board and RCM module), which is defined in a BOARD_HEADER file. This file is named dev0455.h and located in the folder

....\Ember\EmberZNet2.5.0\hal\micro\xap2b\em250\board\

IMPORTANT: Because the use and settings of GPIOs on the PAN4570 testboard is different another BOARD_HEADER file is required.

After installation of EmberZNet2.5.0 the required change of the BOARD_HEADER file can be done as follows:

Rename the dev0455.h extracted with EmberZNet for example in dev0455_ember.h
Copy the PAN4570.h file from the cd to the location where dev0455.h was located
Rename the PAN4570.h file to dev0455.h

PAN4570.h enables D11, D14, SW2 and SW6 connected to PAN4570 for the use of the "simple-lighting" sample application.

The two switches and two LEDs are used as follows:

board	LED	GPIO	Ember™ name	function
LIGHT	D11	3	HEARTBEAT_LED	heartbeat
LIGHT	D14	12	LIGHT	LIGHT
LIGHT	SW2	15	BUTTON 1	LIGHT ON and networking
LIGHT	SW6	8	BUTTON 0	LIGHT OFF and networking
SWITCH	SW2	15	BUTTON 1	LIGHT ON
SWITCH	SW6	8	BUTTON 0	LIGHT OFF

(Table 4)

For custom applications 5 buttons and 4 LEDs are available on the testboard, the carrierboard/testboard schematics in part 10 show their connections to the GPIOs. Changes regarding the GPIOs should always be done only in the BOARD_HEADER file.

European Technology Center Panasonic Electronic Devices (EUROPE) GmbH	APPROVED genehmigt	CHECKED geprüft	DESIGNED Erstellt
--	-----------------------	--------------------	----------------------

CLASSIFICATION Einstufung	No. DS-Eval4570-2400	REV. C
SUBJECT Thema	EvalBoard PAN4570	
CUSTOMER'S CODE EvalPAN4570	PANASONIC'S CODE	DATE Datum
		11 of 20
		06.11.2006

8.4. EMBER™ INSIGHT ADAPTOR CONFIGURATION

The Ember™ Insight Adaptor is used for programming and debugging of PAN4570 application software. As delivered the Adaptor is configured to support DHCP, in case your site is configured for static IP addresses the Adaptor has to be configured for static IP address as well.

In order to to configure the Insight Adaptor for static IP address do the following steps: Connect a USB cable from your pc to the InSight adapter's USB connector.

On the pc run a standard terminal emulation program to connect to the InSight adapter (the InSight adapter appears as a COM port).

Remark: Using the USB connection as a serial communication connection might require a driver for USB<->serial. This driver can be aquired from FTDI: <http://www.ftdichip.com/Drivers/VCP.htm>

Configure your terminal emulator with the settings :

115200 (baud)

8 (data bits)

n (no parity)

1 (stop bit)

Flow Control = None

Issue the following InSight adapter commands through the terminal emulator:

```
ip_static <ipaddress> <netmask> <gateway>
ip_dhcp off
```

For more details see also [5]

Important: Press the red RESET button on the front of the InSight Adaptor or reset the Adaptor by unplugging/plugging the dc supply plug.

9. EMBER ZIGBEE IMPLEMENTATION

9.1 FLASH PROGRAMMING OF PAN4570

The following steps describe the use of the Ember™ Insight Adaptor as programmer.

1. Check the latest documentation on the Ember™ tools (see also part 9.1.)
2. Install the EmberZNet™ (currently Version 2.5.0) package on your PC
Install Ember™ xIDE.
3. Check if DHCP should be ON or OFF according to 8.4.

4. **Important:**

Because the Ember™ Insight Adaptor provides power to PAN4570, remove the PAN4570 carrierboard from the ISM transceiver testboard before connecting it to the Ember™ Insight Adaptor. Set the power slide switch on the Ember™ Insight Adaptor to the appropriate (right) position. Power up the Ember™ Insight Adaptor .

European Technology Center Panasonic Electronic Devices (EUROPE) GmbH	APPROVED genehmigt	CHECKED geprüft	DESIGNED Erstellt
--	-----------------------	--------------------	----------------------

CLASSIFICATION Einstufung	No. DS-Eval4570-2400	REV. C
SUBJECT Thema	EvalBoard PAN4570	
CUSTOMER'S CODE EvalPAN4570	PANASONIC'S CODE	DATE Datum
		12 of 20
		06.11.2006

Connect the Ember™ Insight Adaptor to the SIF connector on the module carrierboard with the grey ribbon cable supplied with the Insight Adaptor. Please make sure that pin1 of the plug connects to pin1 of the header.

5. Connect the Ember™ Insight Adaptor via a USB cable or crossover network cable to the PC where EmberZNet™ is installed on.

Start xIDE.

Within the menue TOOLS\AutoDetectSIF check >Add SIF Pods< and click>Next<.

In the next window >Add new SIF Pod< click >Yes, search for new...<.

In the next window select your network adaptor and click >Next<.

In the next window select the detected SIF pod and click >Next<.

In the next window named >Configuration< click >Next<.

After the configuration the summary should be displayed:

**Attempted to configure Ethernet Pod >address of Pod<
Found slave with no chip select.
Slave with no chip select is XAP2b**

Within the menue TOOLS\Configure_SIF\SIF_configuration you can check for the pods and slave configuration.

6. On your pc create a new folder, for example C:\PAN4570

From the CD subfolder \software copy the following files to C:\PAN4570:

```
em2xx_load.exe
em250-rangetest.xpv
em250-rangetest.xdv
standalone-bootloader-em250.xpv
standalone-bootloader-em250.xdv
```

(Instead of em250-rangetest other applications could be selected)

Below an example for an upload after opening a DOS window on the pc is shown (Ember™ Insight Desktop could be used instead).

The following DOS entries would start the programming of PAN4570 with "Ember™ Range Test Application 2.0" including the embedded bootloader :

```
> cd c:\PAN4570
em2xx_load.exe -erase -btl c:\PAN4570\standalone-bootloader-em250
-Run c:\PAN4570\em250-rangetest
```

For details on using the em2xx_load.exe utility see also [9]

European Technology Center Panasonic Electronic Devices (EUROPE) GmbH	APPROVED genehmigt	CHECKED geprüft	DESIGNED Erstellt
--	-----------------------	--------------------	----------------------

CLASSIFICATION Einstufung		No. DS-Eval4570-2400	REV. C
SUBJECT Thema		EvalBoard PAN4570	
		PAGE Seite	13 of 20
CUSTOMER'S CODE EvalPAN4570	PANASONIC'S CODE	DATE Datum	06.11.2006

The DOS entry window displays the progress of programming and finally displays >SUCCESS<. If not check again steps 3. to 5.

7. Remove the connection of the Insight Adaptor to the PAN4570 carrierboard. Plug the PAN4570 carrierboard to the testboard and push RESET on the testboard
PAN4570 is now ready to run the programmed software. For the em250-rangetest see part 9.3.

European Technology Center Panasonic Electronic Devices (EUROPE) GmbH	APPROVED genehmigt	CHECKED geprüft	DESIGNED Erstellt
--	-----------------------	--------------------	----------------------

CLASSIFICATION Einstufung	No. DS-Eval4570-2400	REV. C
SUBJECT Thema	EvalBoard PAN4570	
CUSTOMER'S CODE EvalPAN4570	PANASONIC'S CODE	DATE Datum
		14 of 20
		06.11.2006

9.2. DEVELOPMENT OF APPLICATIONS

For software development the Insight Desktop™, a comprehensive integrated development environment (IDE) and C-language compiler toolchain from Ember™ Inc. is required. Insight Desktop™ is part of Ember™ development kits and can currently be purchased together with programming adaptors as EM250 jumpstart kit at a price of USD 2500,- directly from Ember™ Inc. (www.ember.com).

The environment works with the preceding EM2420, the EM250 and the upcoming EM260. For code development it comprises the Integrated Development Environment (IDE) named xIDE based on eclipse 3.1.0 for editing, compiling and debugging of C-applications. In addition network visualization and debugging tools are included. For (re-) programming the Ember™ Insight Adaptor is required. This adaptor has to be linked to the computer where the Ember™ Insight Desktop is installed on over an Ethernet network connection. The SIF interface cable delivered with the Insight Adaptor can directly connect to the 10 pin header named SIF on the PAN 4570 carrierboard. Before connecting PAN4570 to the Ember™ Insight Adaptor study the latest Ember™ Insight Adaptor documentation. The following pins of PAN4570 are connected to the signals on the debug connector of the Ember™ Insight adaptor:

PAN4570 pin	PAN4570 signal name	Insight Adapter signal name
various	ground	ground
1 ⁽¹⁾	VBAT	3.0Vdc
3	RESET	RSTB
25	SIF_CLK	SIF_CLK
26	SIF_MISO	SIF_MISO
27	SIF_MOSI	SIF_MOSI
28	SIF_LOADB	SIF_LOADB
as packet trace interface (PTI) also connect the following signals:		
10	GPIO4	GPIO4
11	GPIO5	GPIO5

(1) only if the Ember™ Insight Adaptor is set to powering the target device PAN4570

9.3. EMBER™ ZIGBEE STACK

EmberZNet (currently version 2.5.0) is the ZigBee stack provided with EM250. It supports as networking topologies true mesh, star and cluster networks. As ZigBee devices ZigBee Coordinator, ZigBee Full Functional Device and ZigBee End Devices are supported.

For the ease of application programming EmberZNet is controlled by the application over API commands. Direct ZigBee APS layer APIs are provided for applications that require low level ZigBee control.

According to [3] each ZigBee device has a unique address. This address has to be used by the device and is stored on the EM250 in PAN4570.

European Technology Center Panasonic Electronic Devices (EUROPE) GmbH	APPROVED genehmigt	CHECKED geprüft	DESIGNED Erstellt
--	-----------------------	--------------------	----------------------

CLASSIFICATION Einstufung	No. DS-Eval4570-2400	REV. C
SUBJECT Thema	EvalBoard PAN4570	
CUSTOMER'S CODE EvalPAN4570	PANASONIC'S CODE	DATE Datum
		15 of 20
		06.11.2006

For more information on the items above see the website of Ember™ Inc. (www.ember.com) and the documentation included in the Ember™ Insight Desktop package as part of the Ember™ development kits.

9.4. TESTING FOR IEEE802.15.4 PARAMETERS

The software on PAN4570 as delivered is the >Ember™ Range Test Application 2.0< (Version 1. Oct. 2006) utility. It allows the basic RF transceiver testing including range testing.

The basic operation of Ember™ Range Test Application is as follows. Typing HELP and >return< on the terminal will display a complete list of commands, below the mostly used commands are explained.

e	exit, leaving the last funktion
channel x	channel entry, where x=b sets the lowest channel at 2405MHz x=12 sets a channel at 2440MHz x=1a sets the highest channel at 2480MHz
txtone	turns on an unmodulated carrier
txstream	turns on a continuously modulated carrier
transmit x	transmission of packets according to IEEE802.15.4
receive	reception of packets (requires another device set to transmit on the same channel) <i>remark:</i> for resetting the packet error counter to zero the transmitter has to be restarted
txpow	after RESET the maximum default Tx power of +3dBm is set. with
Txpowermode 1 0	the BOOST MODE with Tx higher output power and higher Rx sensitivity is enabled. BOOST MODE is only allowed for PAN4570 versions with pad or U.FL RF terminal. Hardware RESET or Txpowermode 0 0 returns the module to NORMAL MODE

All available commands are shown after typing HELP >return<., or as document on the CD.

European Technology Center Panasonic Electronic Devices (EUROPE) GmbH	APPROVED genehmigt	CHECKED geprüft	DESIGNED Erstellt
--	-----------------------	--------------------	----------------------

CLASSIFICATION
Einstufung

No.
DS-Eval4570-2400

REV.
C

SUBJECT
Thema
EvalBoard PAN4570

PAGE
Seite
16 of 20

CUSTOMER'S CODE
EvalPAN4570

PANASONIC'S CODE

DATE
Datum
06.11.2006

10. SCHEMATIC OF THE ISM RF TRANSCEIVER TESTBOARD

10.1 SHEET 1

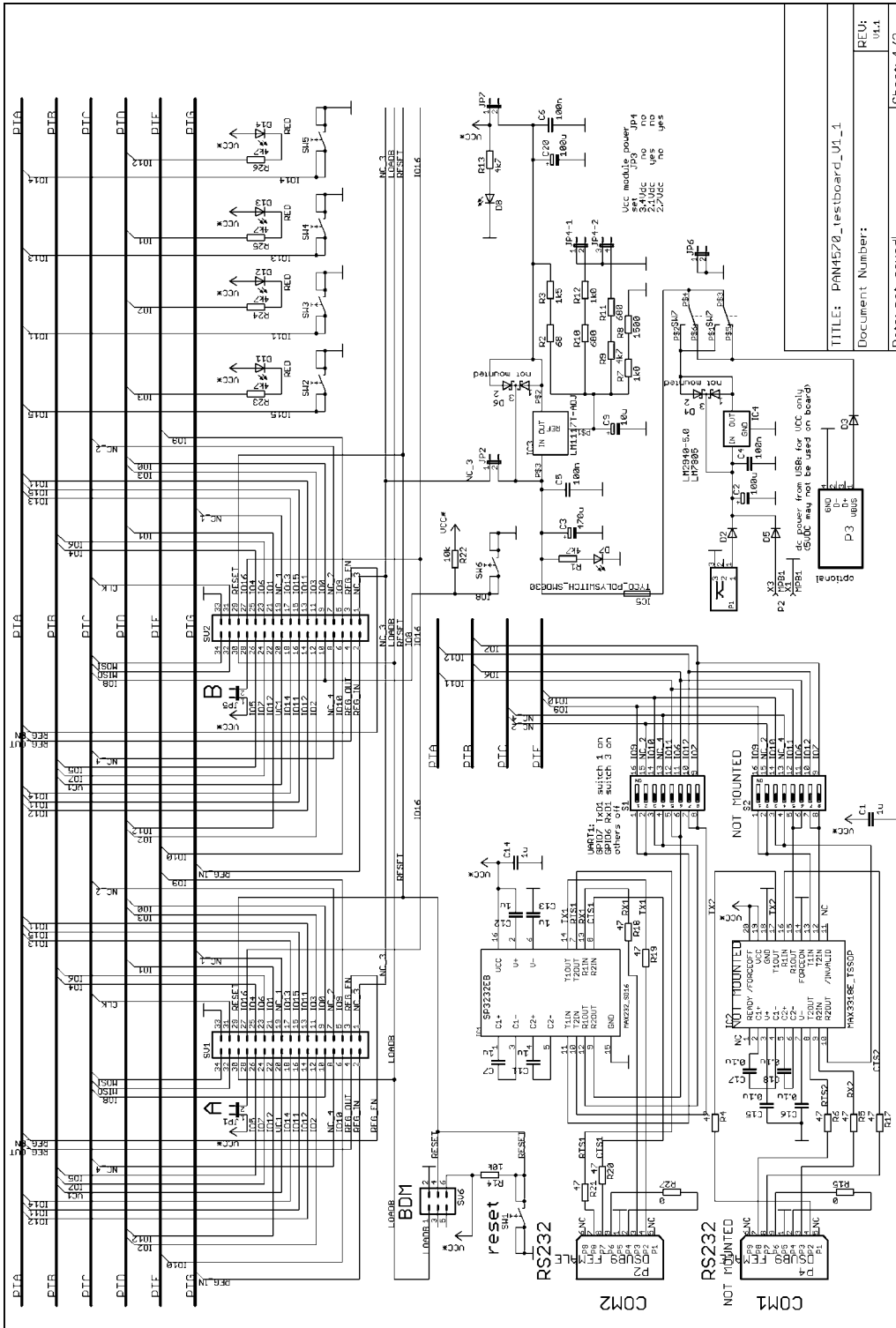

TITLE: PAN4570_Testboard_U1_1
 Document Number:
 Date: not saved!

UCC module power
 set UCC1177-ML
 24VDC
 2.7VDC
 4VDC
 5VDC

OPTIONAL
 P3 USB
 END
 D1
 D2
 D3

NOT MOUNTED
 UCC
 24VDC
 2.7VDC
 4VDC
 5VDC

NOT MOUNTED
 COM1
 COM2
 RS232
 RS485

European Technology Center
 Panasonic Electronic Devices (EUROPE) GmbH

APPROVED
 genehmigt

CHECKED
 geprüft

DESIGNED
 Erstellt

CLASSIFICATION
Einstufung

No.
DS-Eval4570-2400

REV.
C

SUBJECT
Thema
EvalBoard PAN4570

PAGE
Seite
18 of 20

CUSTOMER'S CODE
EvalPAN4570

PANASONIC'S CODE

DATE
Datum
06.11.2006

10.3. PAN4570 CARRIERBOARD

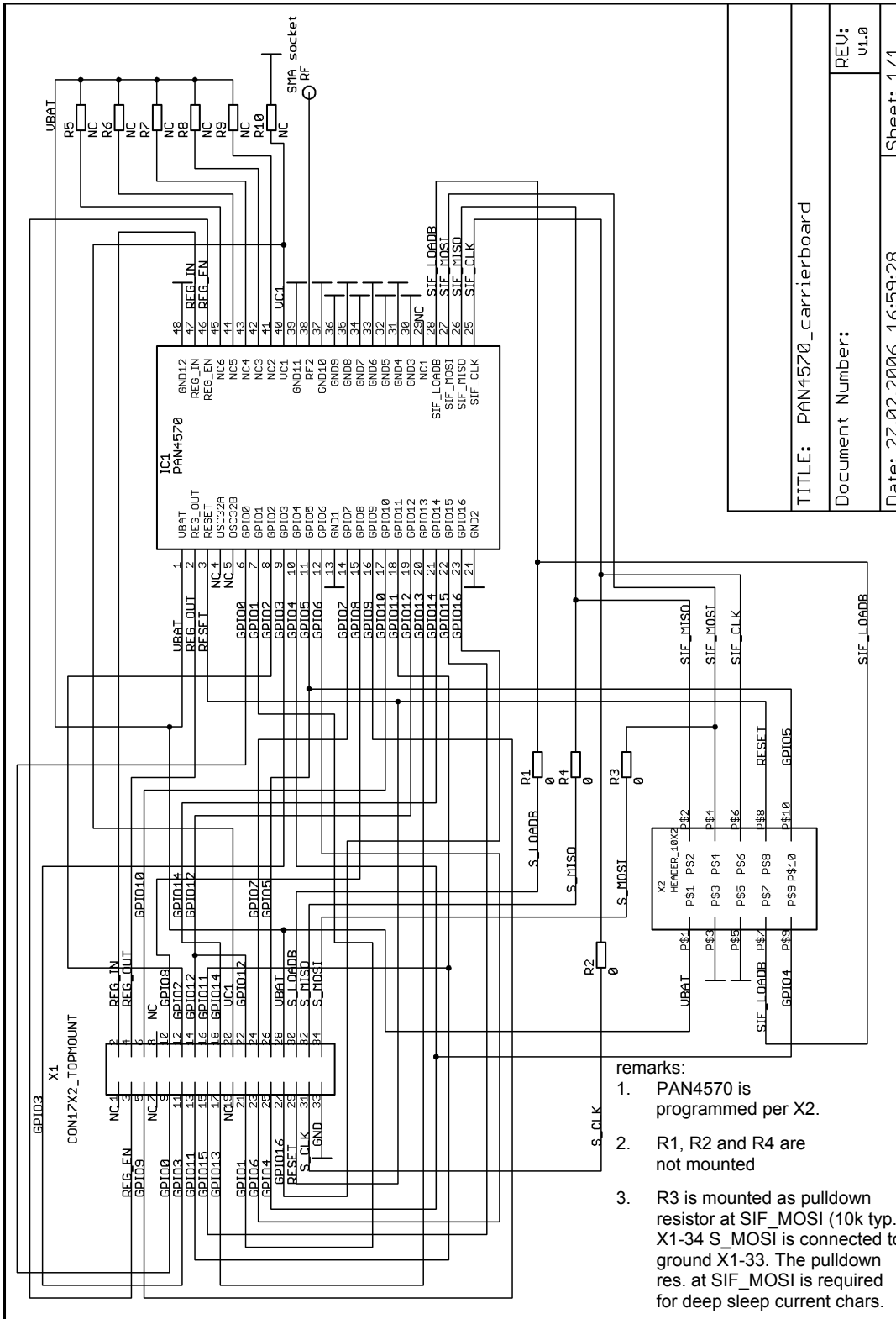

TITLE: PAN4570_carrierboard

Document Number:

Date: 27.02.2006 16:59:28

REV:
v1.0

Sheet: 1/1

European Technology Center
Panasonic Electronic Devices (EUROPE) GmbH

APPROVED
genehmigt

CHECKED
geprüft

DESIGNED
Erstellt

CLASSIFICATION Einstufung		No. DS-Eval4570-2400	REV. C
SUBJECT Thema		EvalBoard PAN4570	
		PAGE Seite	19 of 20
CUSTOMER'S CODE EvalPAN4570	PANASONIC'S CODE	DATE Datum	06.11.2006

11. RELATED DOCUMENTS

- [1] Data sheet PAN4570 DS-4570-2400-102-01 19/05/2006
- [2] Data Sheet Ember™ EM250 Transceiver Version Rev. 5
- [3] IEEE Std. 802.15.4™ –2003

The following documentation can be found as part of the installed EmberZNet package:

- [4] Ember™ Developer Kit User's Guide, 23 June 2006, Ember™ 120-4002-0002D
- [5] InSight Adaptor Technical Specification, 3 May 2006, Ember™ 120-2002-000D
- [6] Using the Standalone Bootloader, AN5013, 30 June 2006, Ember™ 120-5013-000A
- [7] EmberZNet Application Developer's Guide, 29 June 2006, Ember™ 120-0066-0001
- [8] CompilingAppsEM250, 9 June 2006, Ember™ 120-5018-000D
- [9] Developing Ember™ Applications: EM250 Microprocessor, Ember™ 120-5018-000D

12. DOCUMENT STATUS

This information is preliminary.

13. HISTORY FOR THIS DOCUMENT

Revision Version	Date Datum	Modification / Remarks Änderungen / Bemerkungen
A	30.06.2006	Initial version
B	11.09.2006	part 10: updated signal names in testboard schematic and added module carrierboard schematic
C	06.11.2006	Several slight changes and updates. Changed remark on 10.3.

European Technology Center Panasonic Electronic Devices (EUROPE) GmbH	APPROVED genehmigt	CHECKED geprüft	DESIGNED Erstellt
--	-----------------------	--------------------	----------------------

CLASSIFICATION Einstufung		No. DS-Eval4570-2400	REV. C
SUBJECT Thema		EvalBoard PAN4570	
CUSTOMER'S CODE EvalPAN4570		PANASONIC'S CODE	DATE Datum
			20 of 20
			06.11.2006

14. GENERAL INFORMATION

This product description does not lodge the claim to be complete and free of mistakes. Please contact the related product manager in every case.

If we deliver samples to the customer, these samples have the status Engineering Samples. This means, the design of this product is not yet concluded. Engineering Samples may be partially or fully functional, and there may be differences to be published Data Sheet. Engineering Samples are not qualified and are not to be used for reliability testing or series production.

Waiver:

Customer acknowledges that samples may deviate from the Data Sheet and may bear defects due to their status of development and the lack of qualification mentioned above.

Panasonic Electronic Devices (Europe) GmbH rejects any liability or product warranty for Engineering Samples. In particular, Panasonic Electronic Devices (Europe) GmbH waives liability for damages caused by

- the use of the Engineering Sample other than for Evaluation Purposes, particularly the installation or integration in an other product to be sold by Customer,
- deviation or lapse in function of Engineering Sample,
- improper use of Engineering Samples.

Panasonic Electronic Devices (Europe) GmbH waives any liability for consequential and incidental damages. In case of any questions, please contact your local sales partner or the related product manager.

15. LIFE SUPPORT POLICY

This Panasonic Electronic Devices (Europe) GmbH product is not designed for use in life support appliances, devices, or systems where malfunction can reasonably be expected to result in a significant personal injury to the user, or as a critical component in any life support device or system whose failure to perform can be reasonably expected to cause the failure of the life support device or system, or to affect its safety or effectiveness. Customers using or selling these products for use in such applications do so at their own risk and agree to fully indemnify Panasonic Electronic Devices (Europe) GmbH for any damages resulting.

European Technology Center Panasonic Electronic Devices (EUROPE) GmbH	APPROVED genehmigt	CHECKED geprüft	DESIGNED Erstellt
--	-----------------------	--------------------	----------------------